

SS32B THRU SS320B



SCHOTTKY BARRIER RECTIFIER

Reverse Voltage - 20 to 200 Volts
Forward Current - 3.0Amperes

FEATURES

- Plastic package has Underwriters Laboratory Flammability Classification 94V-0
- Metal silicon junction ,majority carrier conduction
- For surface mount applications
- Low power loss ,high efficiency
- High current capability ,Low forward voltage drop
- Low profile package
- built-in strain relief ,ideal for automated placement
- For use in low voltage ,high frequency inverters, free wheeling ,and polarity protection applications
- High temperature soldering guaranteed:260°C/10 seconds at terminals

MECHANICAL DATA

- Case: JEDEC SMB(DO-214AA) molded plastic body
- Terminals: solder plated ,solderable per MIL-STD-750,method 2026
- Polarity: color band denotes cathode end
- Weight: 0.003ounce,0.093 gram

SMB(DO-214AA)

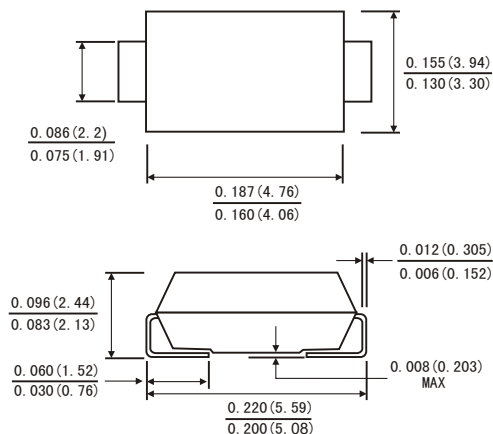

Dimensions in inches and (millimeters)

MAXIMUM RATINGS AND ELECTRICAL CHARACTERISTICS

(Ratings at 25°C ambient temperature unless otherwise specified ,Single phase ,half wave ,resistive or inductive load. For capacitive load,derate by 20%.)

	Symbols	SS 32B	SS 33B	SS 34B	SS 35B	SS 36B	SS 38B	SS 310B	SS 315B	SS 320B	Volts
Maximum repetitive peak reverse voltage	V _{RRM}	20	30	40	50	60	80	100	150	200	Volts
Maximum RMS voltage	V _{RMS}	14	21	28	35	42	57	71	105	140	Volts
Maximum DC blocking voltage	V _{DC}	20	30	40	50	60	80	100	150	200	Volts
Maximum average forward rectified current 0.375"(9.5mm) lead length (See Fig.1)	I(AV)	3.0									Amps
Peak forward surge current 8.3ms single half sine-wave superimposed on rated load (JEDEC method)	I _{FSM}	80.0									Amps
Maximum instantaneous forward voltage at 3.0 A(Note 1)	V _F	0.55		0.75		0.85		0.90		0.95	Volts
Maximum instantaneous reverse current at rated DC blocking voltage(Note 1)	I _R	0.2									mA
		20			10						
Typical junction capacitance(Note 3)	C _J	250			160						Pf
Typical thermal resistance (Note 2)	R _{θJA}	55.0									°C/W
	R _{θJL}	17.0									
Operating junction temperature range	T _J	-65 to+150									°C
Storage temperature range	T _{STG}	-65 to+150									°C

Notes: 1.Pulse test: 300 μs pulse width,1% duty cycle

2. P.C.B. mounted 0.55 X 0.55"(14 X 14mm)copper pad areas

3. Measured at 1MHz and reverse voltage of 4.0volts

FIG.1-FORWARD CURRENT DERATING CURVE

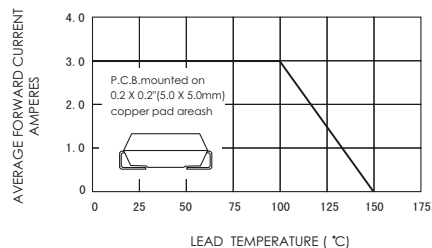

FIG.2-MAXIMUM NON-REPETITIVE PEAK FORWARD SURGE CURRENT

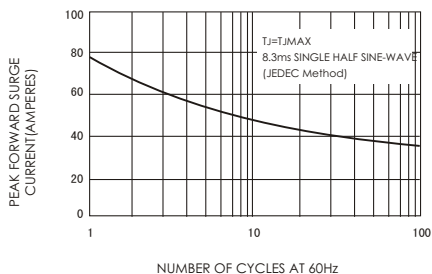

FIG.3-TYPICAL INSTANTANEOUS FORWARD CHARACTERISTICS

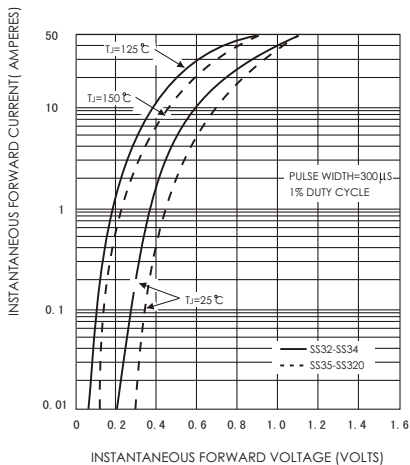

FIG.4-TYPICAL REVERSE CHARACTERISTICS

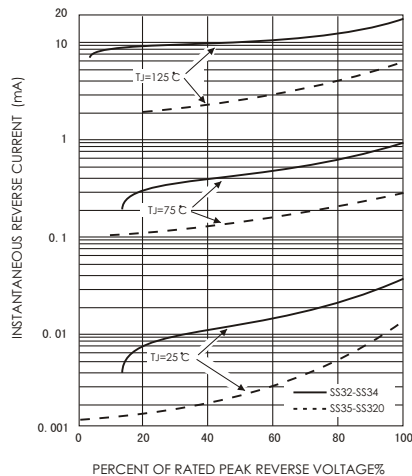

FIG.5-TYPICAL JUNCTION CAPACITANCE

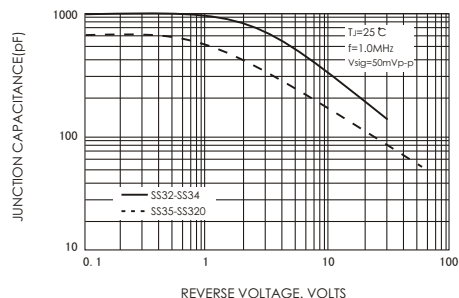

FIG.6-TYPICAL TRANSIENT THERMAL IMPEDANCE

